

SITE AREA STATEMENT				
DESCRIPTION	AREA IN SQ.MT.	AREA IN SQ.YD.	%	AREA IN ACRE
TOTAL AREA OR LAND = (A)	41733.141	49912.836	100	10.3125
AREA UNDER 75.0M WIDE ROAD WIDENING = (B)	272.433	325.830	0.0673	
AREA UNDER 30.0M GREEN BELT (INCLUDING 12.0M WIDE SERVICE ROAD) (0.0999 ACRE + 0.705 ACRE) = (C)	689.785	824.983	0.1704	
TOTAL AREA UNDER 75.0M WIDE ROAD +30.0M GREEN BELT (B+C) = D	962.218	1150.813	0.2377	
BALANCE SITE AREA (A - D) = E	40770.923	48762.023		10.0748
ADD 50% AREA OF 30.0M GREEN BELT & 75.0M M WIDE SECTOR ROAD (962.218/2) = F	481.109	575.406	0.11885	
NET PLANNING AREA (E+F) = G	41252.032	49337.430		10.19365
PERMISSIBLE PLOTTING AREA @61% ON NET PLANNING = (G)	25163.739	30095.832	61.00%	6.21813
PROPOSED PLOTTING AREA	22544.370	26963.067	54.65%	5.57084
REQUIRED AREA FOR COMMUNITY FACILITIES @ 10% OF TOTAL SITE AREA = (A)	4173.314	4991.284	10.00%	1.03125
PROVIDED AREA FOR COMMUNITY FACILITIES	4173.770	4991.829	10.00%	1.03136
REQUIRED GREEN AREA @ 7.5% OF TOATAL SITE AREA = (A)	3129.986	3743.463	7.50%	0.77344
PROVIDED GREEN AREA	3130.040	3743.528	7.50%	0.77345
PERMISSIBLE COMMERCIAL AREA @ 4% ON NET PLANNING = (G)	1650.081	1973.497	4.00%	0.40775
PROPOSED COMMERCIAL AREA	1649.860	1973.233	4.00%	0.40769
PERMISSIBLE DENSITY	240-400	PPA		
PROPOSED DENSITY = (187 X 13.5) = 2524.50/10.19362	247.654	PPA		

PLOTS AREA CALCULATIONS

S.NO.	PLOT NO.	COEFF.	LENGTH (m)	WIDTH (m)	PLOT AREA (SQ.M)	PLOT AREA (SQ.YD.)	NO.S	TOTAL AREA (SQ.M)	TOTAL AREA (SQ.YD.)	
1	1-18	1	18.000	X	7.000	126.000	150.696	23	2898.000	3466.011
2	19-20	1	18.000	X	7.905	142.290	170.179	2	284.580	340.366
3	26-33	1	16.465	X	6.455	106.282	127.113	8	850.250	1016.900
4	34	0.5	0.107	X	6.455	0.686	0.820	1	0.690	0.820
		1	16.358	X	6.455	105.591	126.287	1	105.590	126.287
5	35	0.5	16.358	X	13.627	111.455	133.300	1	111.460	133.300
6	36-45	1	16.450	X	6.455	106.185	126.997	20	2123.700	2539.940
7	56-77	1	19.800	X	7.262	143.788	171.970	2	287.580	343.940
8	57-66	1	19.800	X	7.285	144.243	172.515	20	2884.860	3450.290
9	78-81	1	18.000	X	7.000	126.000	150.696	15	1890.000	2260.440
10	82	1	18.000	X	7.095	127.710	152.741	1	127.710	152.741
11	94-107	1	18.000	X	7.000	126.000	150.696	14	1764.000	2109.740
12	108	1	18.000	X	7.613	137.034	163.893	1	137.030	163.890
13	109	1	15.530	X	6.613	102.700	122.829	1	102.700	122.830
14	110-124	1	15.530	X	6.600	102.498	122.588	15	1537.470	1838.810
15	125-139	1	15.526	X	6.600	102.472	122.556	15	1537.070	1838.340
16	140	1	15.526	X	6.613	102.673	122.797	1	102.670	122.800
17	141-143	1	18.000	X	7.765	139.770	167.165	3	419.310	501.490
18	144	1	18.000	X	7.761	139.698	167.079	1	139.700	167.080
19	145-154	1	18.000	X	6.700	120.600	144.238	19	2291.400	2740.510
20	155	0.5	18.000	X	6.850	118.557	141.794	1	118.560	141.790
21	156	0.5	18.000	X	6.970	120.690	144.345	1	120.690	144.350
22	167-176	1	18.000	X	6.820	122.760	146.821	20	2455.200	2936.420
23	177-188	1	18.000	X	7.060	127.080	151.988	2	254.160	303.980
23	166, 187	1	18.000	X	7.060	127.080	151.988	2	254.160	303.980
X								187	22544.370	26963.067
										5.57084

KRISHI VIGYAN KENDER

(AREA FREEZE SHOWN THUS 50%) FOR TOTAL SALEABLE PLOTS AREA

S.NO.	PLOT NO.	COEFF.	LENGTH (m)	WIDTH (m)	PLOT AREA (SQ.M)	PLOT AREA (SQ.YD.)	NO.S	TOTAL AREA (SQ.M)	TOTAL AREA (SQ.YD.)	
1	13-18	1	18.000	X	7.000	126.000	150.696	11	1386.000	1657.660
2	19-20	1	18.000	X	7.905	142.290	170.179	2	284.580	340.366
3	36-39	1	16.450	X	6.455	106.185	126.997	8	849.480	1015.980
4	56, 77	1	19.800	X	7.262	143.788	171.970	2	287.580	343.940
5	57-66	1	19.800	X	7.285	144.243	172.515	20	2884.860	3450.290
6	78-81	1	18.000	X	7.000	126.000	150.696	4	504.000	602.780
7	94-97	1	18.000	X	7.000	126.000	150.696	4	504.000	602.780
8	109	1	15.530	X	6.613	102.700	122.829	1	102.700	122.830
9	110-123	1	15.530	X	6.600	102.498	122.588	14	1434.970	1716.230
10	125-139	1	15.526	X	6.600	102.472	122.556	15	1537.070	1838.340
11	140	1	15.526	X	6.613	102.673	122.797	1	102.670	122.800
12	141-143	1	18.000	X	7.765	139.770	167.165	3	419.310	501.490
13	144	1	18.000	X	7.761	139.698	167.079	1	139.700	167.080
14	170-176	1	18.000	X	6.820	122.760	146.821	7	859.320	1027.750
X								93	11296.24	13510.30
										2.79136

(15% OF TOTAL SALEABLE PLOTS AREA)

S.NO.	PLOT NO.	COEFF.	LENGTH (m)	WIDTH (m)	PLOT AREA (SQ.M)	PLOT AREA (SQ.YD.)	NO.S	TOTAL AREA (SQ.M)	TOTAL AREA (SQ.YD.)	
1	13-18	1	18.000	X	7.000	126.000	150.696	11	1386.000	1657.660
2	19-20	1	18.000	X	7.905	142.290	170.179	2	284.580	340.366
3	56	1	19.800	X	7.262	143.788	171.970	1	143.790	171.970
4	57-66	1	19.800	X	7.285	144.243	172.515	10	1442.430	1725.150
5	78	1	18.000	X	7.000	126.000	150.696	1	126.000	150.700
X								25	3382.80	4045.83
										0.83591

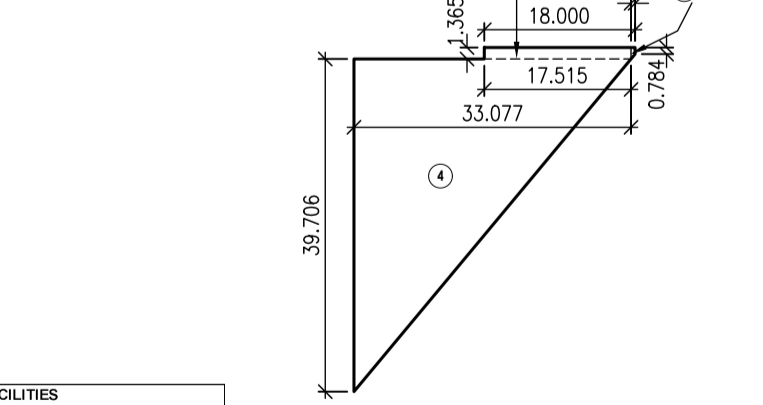
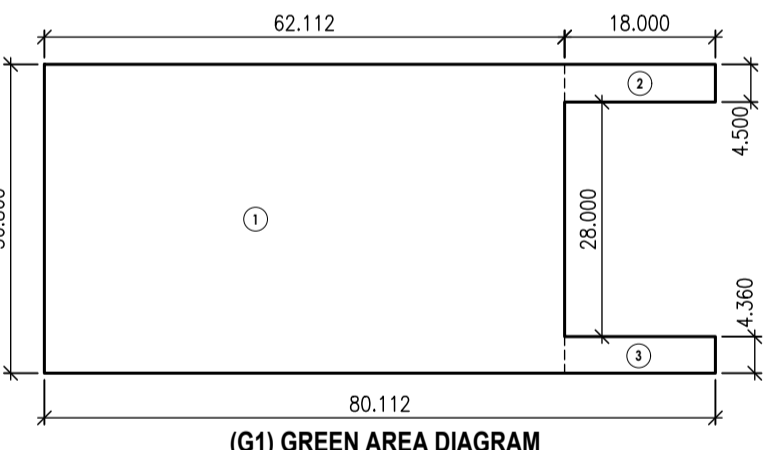
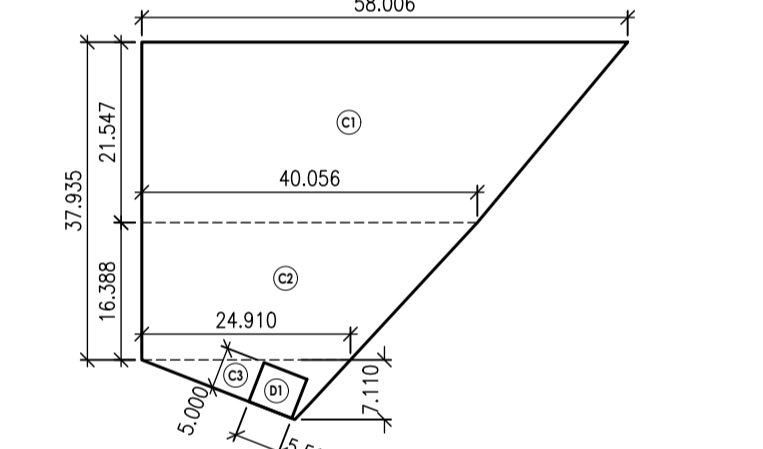
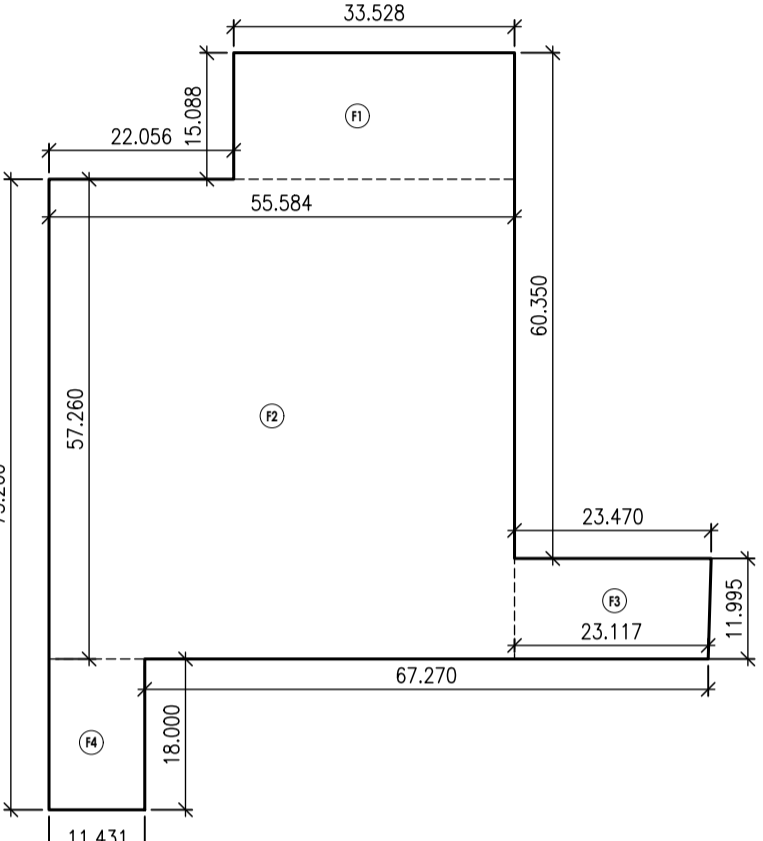

COMMON FACILITIES

CODE	COEFF.	DIM (m)	DIM (m)	NO.S	AREA (SQ.M)	AREA (SQ.YD.)
F1	1	33.528	X 15.088	1	505.87	605.02
F2	1	55.584	X 57.290	1	3182.74	3806.56
F3	0.5	23.470	X 23.117	1	278.41	334.17
F4	1	18.000	X 11.431	1	205.76	249.09
TOTAL COMMON FACILITIES AREA					4173.77	4991.83

COMMERCIAL

CODE	COEFF.	DIM (m)	DIM (m)	NO.S	AREA (SQ.M)	AREA (SQ.YD.)
C1	0.5	58.006	X 40.056	1	1056.47	1283.54
C2	0.5	40.056	X 24.910	1	532.33	636.67
C3	0.5	24.910	X 7.110	1	88.56	105.91
TOTAL ADDITION AREA					1677.36	2006.12
DEDUCTION						
D1	1	5.600	X 5.000	1	28.00	33.49
TOTAL DEDUCTION AREA					28.00	33.49
TOTAL COMMERCIAL AREA					1649.36	1973.63

GREEN

CODE	COEFF.	DIM (m)	DIM (m)	NO.S	AREA (SQ.M)	AREA (SQ.YD.)	
G1	1	1	82.112	X 36.860	1	2289.45	2738.18
G2	1	1	18.000	X 4.500	1	81.00	96.88
G3	1	1	18.000	X 4.360	1	78.48	93.96
G4	0.5	39.706	X 33.077	1	656.68	785.39	
G5	1	1	17.515	X 1.365	1	23.91	28.59
G6	0.5	1.365	X 0.784	1	0.52	0.62	
TOTAL GREEN AREA					3130.04	3743.52	

ESS

CODE	COEFF.	DIM (m)	DIM (m)	NO.S	AREA (SQ.M)	AREA (SQ.YD.)
ESS	0.5	10.448	X 3.445	1	125.04	149.54
TOTAL ESS AREA					125.04	149.54

LEGEND

- 10% OF TOTAL LAND TO GOVT. FOR COMMUNITY FACILITIES
- COMMERCIAL AREA
- GREEN AREA
- E.S.S AREA

LAYOUT PLAN OF PLOTTED COLONY UNDER DEEN DAYAL JAN AWAS YOJANA LAND MEASURING 10.3125 ACRES AT SECTOR-21, VILL. - BIDSUNARWALA, TEH. & DISTT. - JHAJJAR FOR M/S A.D.M DEVELOPERS

TITLE : DEMARCATION PLAN

SCALE:- 1:1000 DATE:- 09-11-2021

OWNER/AUTH. SIGN. ARCHITECT'S SIGN.